

Architectural & Property Guidelines

Revised: 02/04, 03/06, 09/13, 09/15, 02/16, 04/17, 07/17, 09/17,
03/18, 01/19, 3/19, 3/20, 6/20, 10/20, 12/20, 4/21, 8/21, 3/22, 4/22,
3/23, 4/23, 9/23

Cinnamon Lake Association (CLA) uses the Ohio Residential Building Code as the basis for minimum home building requirements. An Environmental or Building permit is required for all new construction, remodels, exterior work, etc. Listed below are additional requirements for all permits, and homes built within Cinnamon Lake.

- Construction activities between November 1st & April 1st, requires adherence to load weight reductions. (*See below for specifications)
- 1200 minimum square feet of above grade living space with a minimum 4/12 roof pitch and a maximum of 18/12. Garage measurements are not included in the required square footage.
- All homes must have an attached or detached garage.
 - Minimum size garage is 14x20 and up to a maximum size of 28x32 either attached or detached.
 - Attached and detached garages must have a roof pitch to match the house.
 - Wall height for garages is 10 feet maximum.
- Roof of a detached garage cannot extend 15 feet or be higher than the house roof. Peak cannot be higher than 15 feet or 5/12 pitch
- Only one (1) attached and one (1) detached garage is permitted with a home, even if multiple lots are owned. Only one (1) shed is permitted per home, even if multiple lots are owned.
- All lots must have a professional survey showing property lines, elevations and benchmarks (topo) and a copy must be provided to the office before work is started.
- Down spouts to be installed and inspected before final grade. This includes new builds, additions, garages, etc. Downspouts must run to the ditch or lake.
- Preapproval is required for any residential metal siding. No vertical, corrugated or roof like metal siding will be permitted on a home or garage.
- No industrial buildings.
- No used structures or used building materials can be used without prior Environmental Committee approval.
- No metal sheds, fencing of property, car ports. (Metal, plastic, canvas, etc.)
- No flat roofs.
- No modular or manufactured homes. Only homes stick built on site.

Color Restrictions:

- **Roofing:** Colors must be approved by the Environmental Committee. No white, bright, or reflective colors.
- **Siding:** Colors must be approved by the Environmental Committee. No black or black-like, white, reflective, or bright colors.
- **Trim:** Colors must be approved by the Environmental Committee. If color is other than white it must blend well with the natural surroundings of Cinnamon Lake.

Set Back Requirements:

- Front: 30 feet from road right of way. (Front lot pins)
- Side: Not less than 10 ft. from side lot line.
- Rear: 20 feet or 25% of lot depth. (Whichever is **smaller**)
Corner or lake lots are an exception

The Environmental Committee may recommend to the Board of Directors reasonable variances or adjustments of these Restrictions where literal application thereof would result in unnecessary hardship. Any such variance or adjustment shall be granted in conformity with the general intent and purposes of these Restrictions and that the granting of a variance or adjustment will not be materially detrimental or injurious to other lots in the Development. The decision by the Board of Directors is final.

Swimming Pools:

Private residential pools are allowed in Cinnamon Lake but must be safely enclosed. Pools are defined as any indoor or outdoor structure, chamber, or tank containing a body of water for swimming, diving, or bathing intended for use by the homeowners and their guests. Broadly, in-ground pool enclosures must comply with Chapter 4101, Section 3109.4.1 through 3109.4.3 of the Ohio Administrative Code (OAC) excepting Section 3109.4.1.5 (Chain Link Dimensions). Chain link fences are not permitted; existing chain link fences are grandfathered until there ceases to be a pool. Any gates must accommodate a locking device, open outward, be self-closing and have a self-latching device with a release mechanism located on the pool side of the gate. Fences must not infringe on lot easements. Above-ground pools must comply with Chapter 4101, Section 3109.4.1.9 of the OAC. If a pool is removed, the pool enclosure must be removed.

Apply: Application is to be made at the Office of Cinnamon Lake during regular business hours. (8:30am to 5pm)

***Weight limits must follow ODOT Regulations:**
<https://www.transportation.ohio.gov/working/publications/OS-8>

APPLYING FOR AN ARCHITECTURAL PERMIT FOR A NEW HOME:

Your accounts with Cinnamon Lake must be current in order to apply for permits.

New home construction architectural permit fee: \$1,250.00

Checks for permit needs to be made payable to Cinnamon Lake Association, Inc. \$250.00 of new home construction permit fee is a security deposit for any damages to Association or private property and may be refunded after final occupancy requirements are met.

Sewer Tap in fee: Contact Rural Lorain County Wastewater District (LORCO) 440-647-4882

Water Tap in fee: Contact Rural Lorain County Water Authority (RLCWA) 1-800-842-1339

Natural Gas: Available in most areas, contact Consumers Gas 330-682-4144

Tree clearing to enable the building process must meet the following requirements to be considered for approval:

- 1) Building footprint must be shown on plot map.
- 2) Survey completed and presented to office.
- 3) Requires architectural construction permit and permit fee paid.
- 4) All tree stumps must be removed or ground down to the level of the yard within the permit time frame.

Side lot pins need to be located and marked with string. The house is to be staked out with proper setbacks. Driveway should be staked out and trees clearly marked for removal. A green 911 address sign needs to be placed at the front of the lot and lakeside, if lakefront.

Paperwork to be included with application:

- 1 set of construction drawings, to include:
 - Foundation Plan
 - Floor Plan
 - 4 Elevations (Detached Garage – 2 elevations)
 - Cross Sections
 - Location of downspouts, sewer and water lines, any culvert over 12 inches or drainage pipe, underground utilities including Geothermal indicated on plot map
- Professional lot survey of the property to include elevations and benchmark (topo) (horizontal control points)
- Color samples of roof & siding choices
- Bank (or loan) confirmation letter or \$5,000.00 building deposit
- Check made payable to Cinnamon Lake Association, Inc. for the architectural permit fee.

Pre-Construction Meeting: Meeting takes place after the plans have been reviewed. The Environmental Committee, the owner and the builder are required to attend this meeting.

Zoning permit: Contact Jackson Township after Cinnamon Lake approves your application. Contact: Jackson Township Zoning, 799 County Rd. 175-Polk, OH.

Permits are good for 6 months from the date of the permit approval. If extensions are necessary, two (2), three-month extensions are available for a charge of \$250.00 each. If both extensions are used, you will be required to reapply for a new permit and go through another pre-construction permit process. The first security deposit will not be refunded. Any other permit not completed within the 6 months will have to re-apply and re-pay for the permit. A permit with no charge that is not completed within the 6 months will have to re-apply for approval.

For any questions or concerns, please call the Cinnamon Lake Office at 419-945-2521

DURING THE BUILDING PROCESS

Association quiet time is 9:00pm to 7:00am.
No contractors will be permitted to enter prior to 7:00am.

A construction driveway is to be installed for heavy equipment prior to the start of any construction. The construction driveway is to be maintained in serviceable condition during all phases of construction.

Some type of driveway is required upon completion of the home and before occupancy. This is to prevent mud and debris from entering the road and ditches.

Address and proper permits must be displayed during construction. Lot(s) must be properly staked off and side lot lines strung prior to construction. All materials and equipment must stay on the building lot itself. Please respect private property and our roads.

A port-a-pot is to be on site before groundbreaking and should remain there until occupancy permit is approved.

A dumpster is required to be on site after the foundation is complete. The dumpster is to be used for all discarded construction materials. The building site needs to be kept clean of debris at all times.

A silt screen must be in place when necessary to keep all materials from entering the lake.

Any changes from the original submitted plans for additions, colors, materials, size etc., or to any submitted permits must be approved by Environmental Committee prior to implementation along with \$25.00 change request fee.

Required inspections: Inspections are to be scheduled with the Office at 419-945-2521. They are to be scheduled at least 24 hours in advance.

- **Footer**-to verify set back and sideline requirements
- **Sewer Tap**-Sewer tap, lateral and connection to house to be inspected before covering. Contact Mike Simmons, 330-466-8562
- **Occupancy**-before moving in
- **Final**-before building deposit is returned

Cinnamon Lake Association, Inc. has the right to RED TAG any construction. Work on the site may not continue until written permission is received from Cinnamon Lake Association, Inc.

Loading and unloading equipment and supplies on a curve or hilltop shall require the assistance of traffic control. No trucks or equipment may be parked on streets or right of ways. No track or crawler type vehicles may be driven on any of the roads.

The owner and/or builder will be held responsible for road damage or right of way damage including mud and debris. The road must be cleaned as needed to keep mud off of roadways.

Load limits are in effect from November 1st to April 1st. A reduction in weight applies during this time. Check with the office before you make arrangement for heavy trucks to enter. (See weight limits table on second page.)

All dumpsters, materials, debris, and equipment must stay on the lot being built upon and emptied as needed so that it does not become over full. Do not use adjoining lots at any time for any reason.

**AFTER THE FINAL OCCUPANCY REQUIREMENTS ARE MET AND BEFORE THE DEPOSIT IS RETURNED
THE FOLLOWING MUST BE MET:**

The dumpster and port-a-pot should be removed.

The propane tank must be enclosed or screened as per the Declarations, pg. 6, F.

All decks, railings, steps, and entrance ways must be completed.

The final grade must be complete to include the road ditch to be inspected and approved by the maintenance department, and the lawn seeded.

The house numbers must be permanently affixed to the house a or a green 911 address sign placed by the road.

All construction debris must be removed.

Any dead trees or underbrush must be cleaned out and removed.

Architectural Permit Fees

| | |
|--|------------|
| NEW HOME CONSTRUCTION..... | \$1,250.00 |
| (\$250.00 Refunded after final occupancy requirements are met) | |
| EXTENSION FEE..... | \$250.00 |
| CHANGE REQUEST FEE..... | \$25.00 |
| SEWER TAP IN FEE-CONTACT LORAIN COUNTY RURAL WASTEWATER DISTRICT(LORCO) (Call 440-647-4882 for price) (See attached guidelines) | |
| WATER TAP IN FEE-CONTACT RURAL LORAIN COUNTY WATER AUTHORITY (Call 1-800-842-1339 or 440-355-5121 for price) | |
| REMODELING/ADDITIONS..... | \$190.00 |
| The requirements for minimum square footage and minimum garage size cannot be reduced with a remodel. | |
| DETACHED GARAGE | \$190.00 |
| (Max. size is 30 x45 x16) | |
| STORAGE SHED | \$ 65.00 |
| (12X16 Max. W/APPROVED ANCHORS) | |
| BOAT DOCK | \$ 65.00 |
| (Max. extension of 15ft out into lake) | |
| DECK/PATIO..... | \$ 65.00 |
| Above Ground POOL (100 gallons or more) | \$ 65.00 |
| (Verification of placement) | |
| In ground Pool | \$125.00 |
| Misc. Permits including but not limited to: Roofing, siding, deck replacements ... | \$25.00 |
| Tree removal: Permit required, but no fee. | |

Failure to obtain a permit is a \$50.00 fine.

No construction work can begin prior to securing an approved permit. If work is started before a permit is secured or it is determined that work was completed without a permit, a late fee of \$500 for new home or \$50 for all other improvements will be charged.

Work completed without a permit is subject to Environmental Control Committee review and is subject to any required remediation to meet approved building guidelines.

Check with the office prior to any exterior work to verify if there are any permits or Environmental approvals needed. etc.

Any changes to any existing structure must be preapproved by the Environmental Control Committee prior to the start of construction.

Sewer Tap Guidelines: LORCO requires that you put in a new sewer tap following the attached guidelines. You cannot use any existing taps. You are required to bore under the roads, not dig up the roads. Any road damage is the responsibility of the builder and/or homeowner to pay for and/or repair.

CULVERT INSTALLATION – 2019

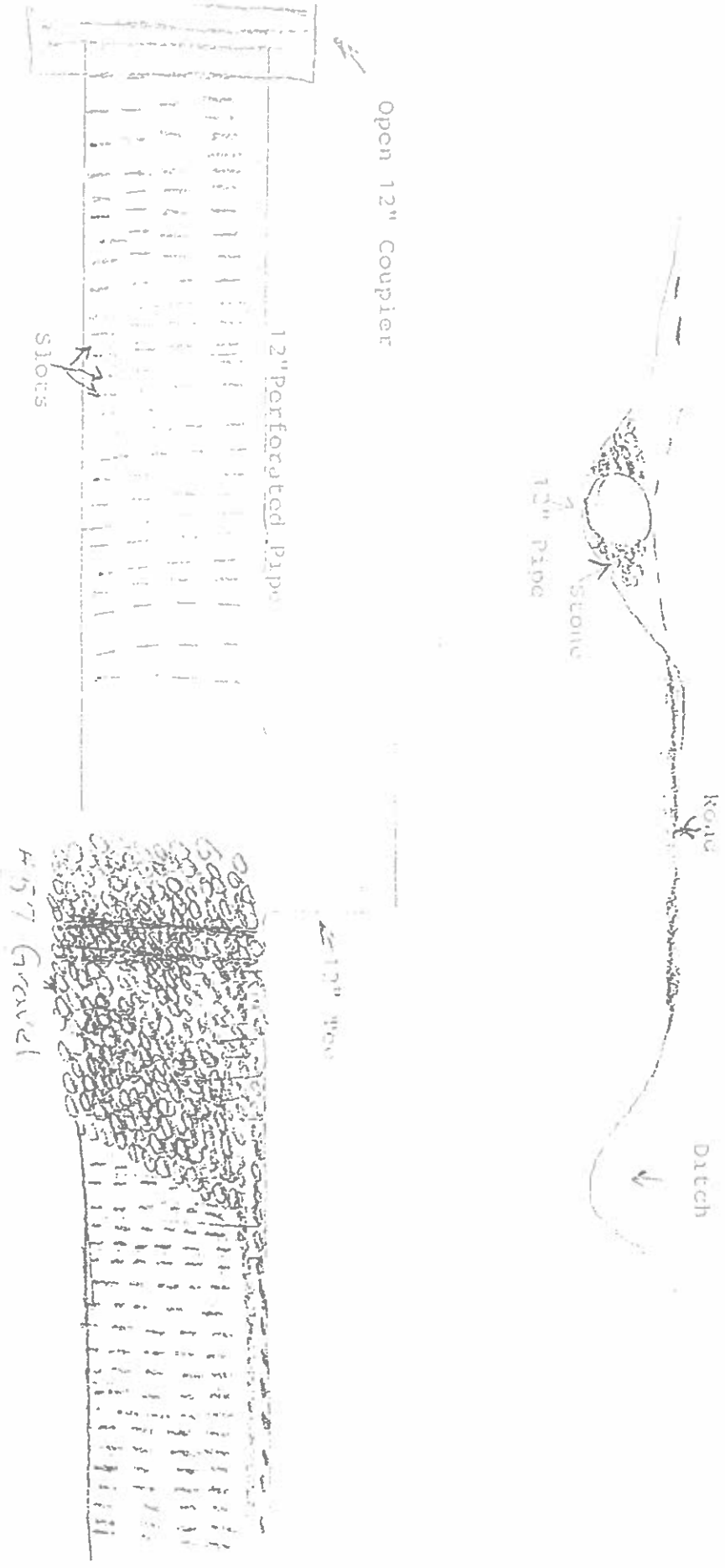

1. An application to the Environmental Control Committee must be submitted and approved before work can start.
2. An inspection must be made by the Maintenance Department **BEFORE** the pipe can be covered.
3. Couplers must be used to connect all sections of pipe.
4. Tees must be installed to serve as a surface drain and cleanout. Tees should be installed every 40 feet.
5. Grate or cover that will allow water into the pipe must be installed.
6. 12-inch perforated pipe must be used to allow drainage under road.
7. 12-inch double walled pipe must be used under driveway.
8. #57 stone must be used to allow water from under and around pipe to drain.
9. Final grade must allow water from road to enter pipe that has been installed.
10. Maintenance must give permission to install driveway pipes and pipes extending along property lines.

Sewer Tap Guidelines

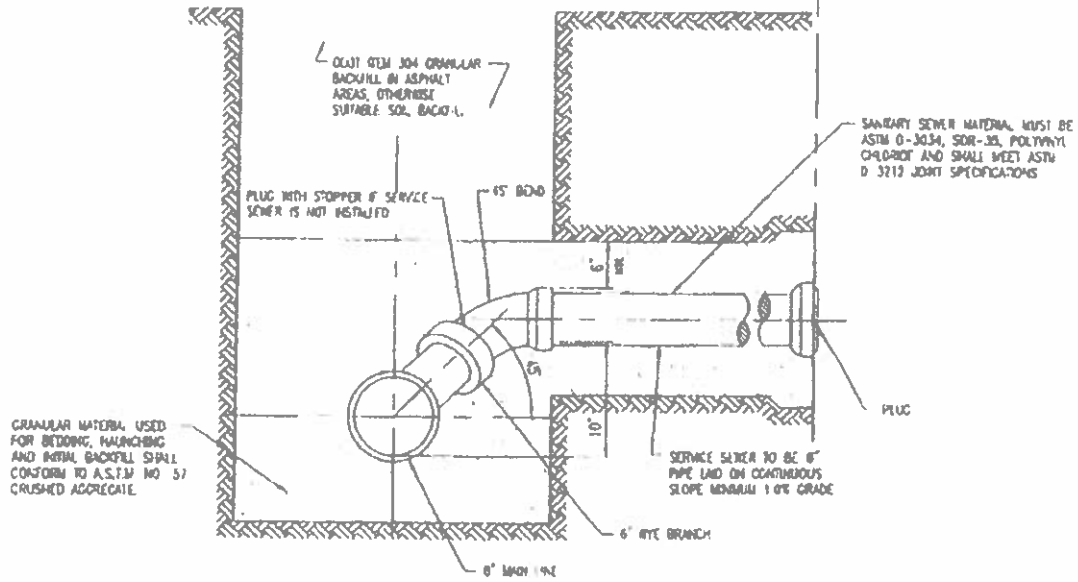
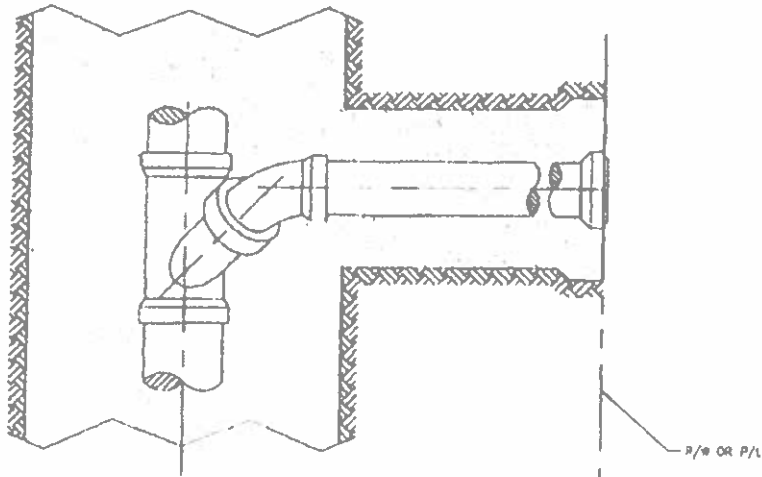

NOTE

2" x 2" HARDWOOD MARKER POLE SHALL BE PLACED AT THE END OF EACH PLUG. THE MARKER POLE SHALL EXTEND FROM THE PIPE PLUG TO A POINT FLUSH WITH THE BACKFILL GROUND SURFACE.



SANITARY SEWER

STANDARD SERVICE CONNECTION

STANDARD
 DWG NO
SAN-1

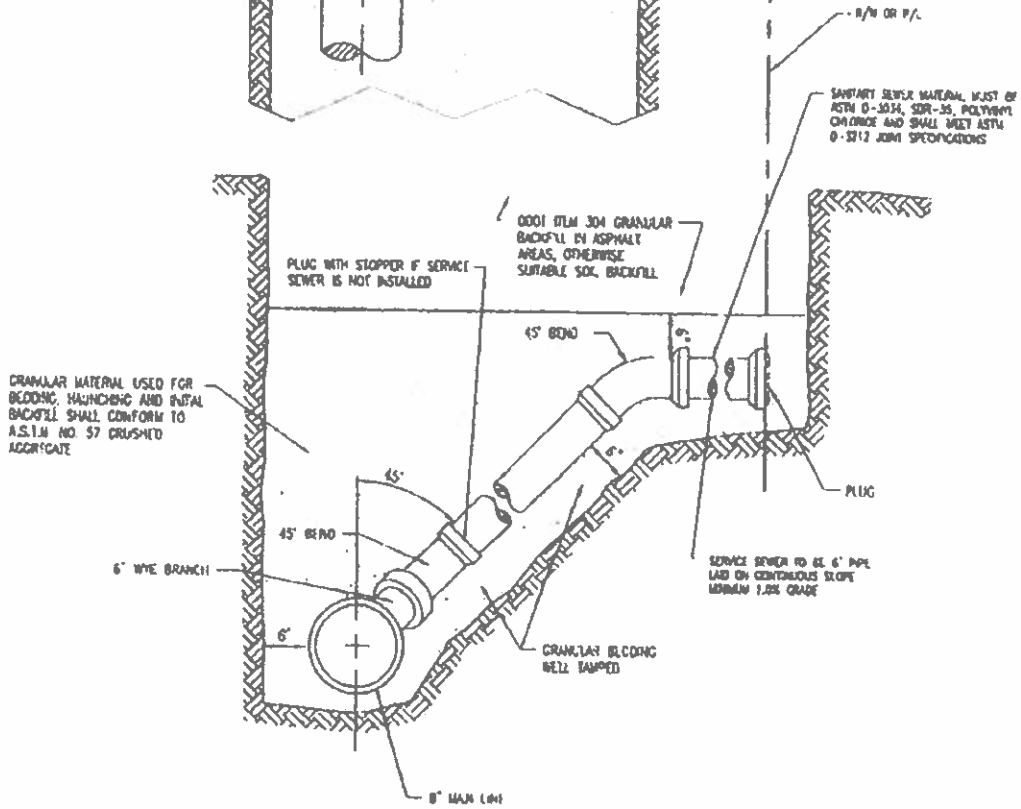
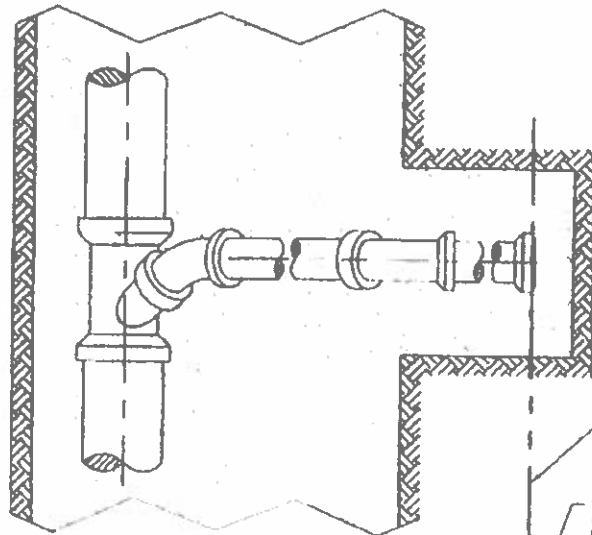

NOTE:

2" x 2" WOODEN MARKER POLE SHALL BE PLACED AT THE END OF EACH PLUG. THE MARKER POLE SHALL EXTEND FROM THE PIPE PLUG TO A POINT FLUSH WITH THE BACKFILL GROUND SURFACE.

| | | |
|---|--------------------------------|--------------------------------|
|  | SANITARY SEWER | |
| | DEEP SERVICE CONNECTION | STANDARD DWG. NO. SAN-2 |

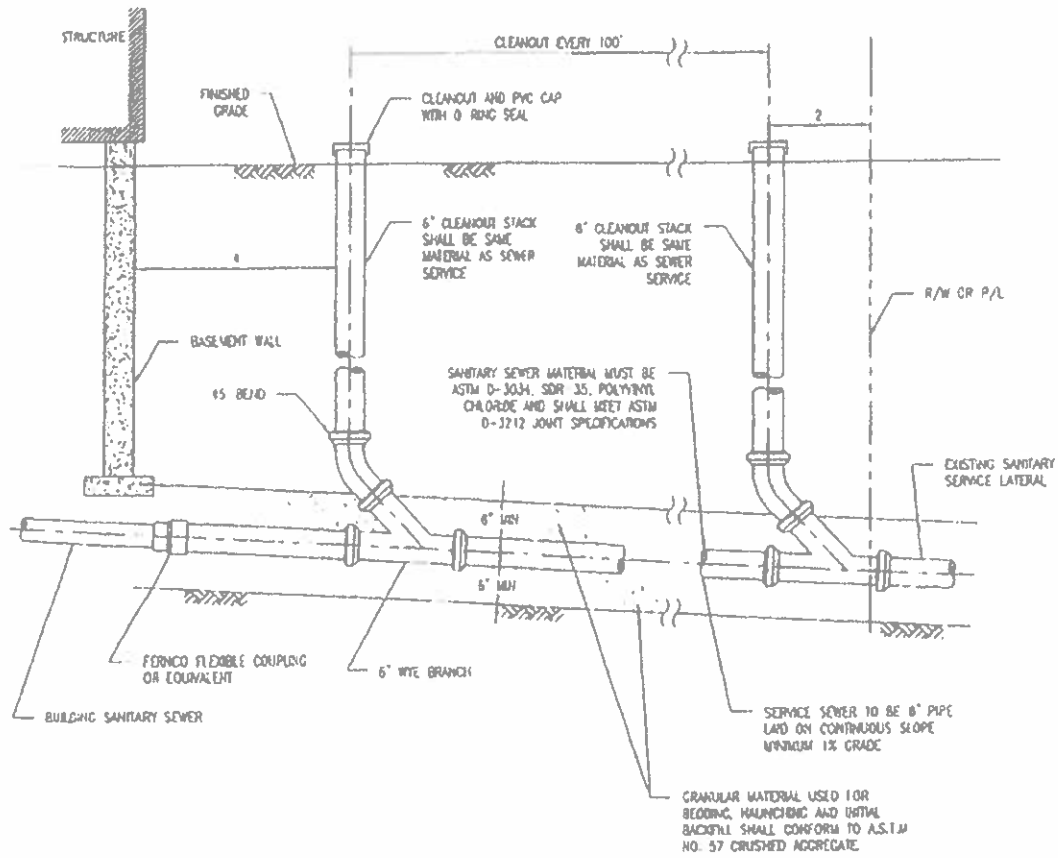

SANITARY SEWER

RESIDENTIAL SEWER
SERVICE INSTALLATION

STANDARD
DWG. NO
SAN-3

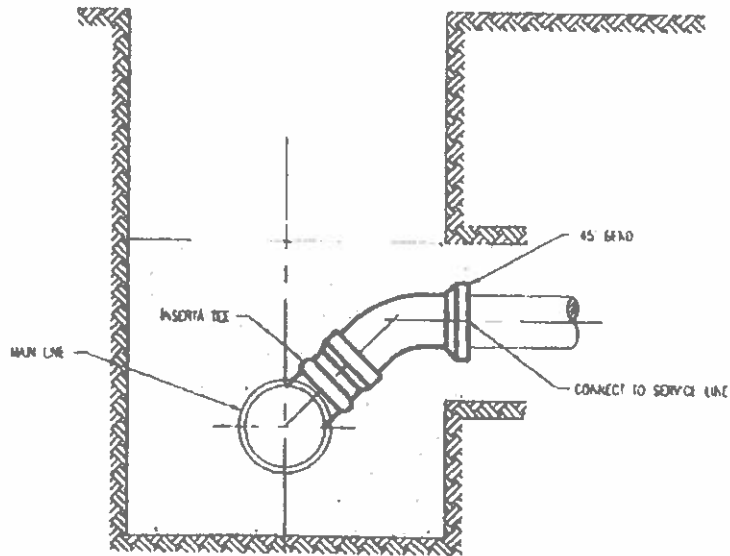
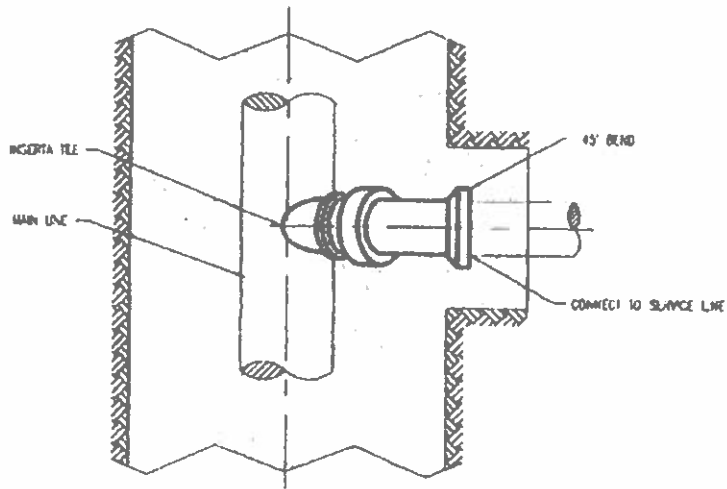

NOTES:

1. 6" INSERTA TEE SLEEVE SHALL BE PROVIDED FOR EXISTING SANITARY SEWER MATERIAL.
2. 6" INSERTA TEE GASKETED PVC HUB SHALL BE FOR ASTM D-3034, SDR-35, POLYVINYL CHLORIDE AND SHALL MEET ASTM D 3212 JOINT SPECIFICATIONS.
3. 6" INSERTA TEE SHALL BE INSTALLED PER MANUFACTURER'S INSTALLATION INSTRUCTIONS AND RECOMMENDATIONS.



SANITARY SEWER

INSERTA TEE INSTALLATION

STANDARD
DWG. NO
SAN-4

FERRICO OR EQUIVALENT FLEXIBLE COUPLING

CUT AND REMOVE SECTION OF EXISTING MAIN SEWER LINE. INSTALL (2) FLEXIBLE COUPLINGS AND (1) PVC WYE (SEE NOTE #1)

FERRICO OR EQUIVALENT FLEXIBLE COUPLING

CONNECT TO SERVICE LINE

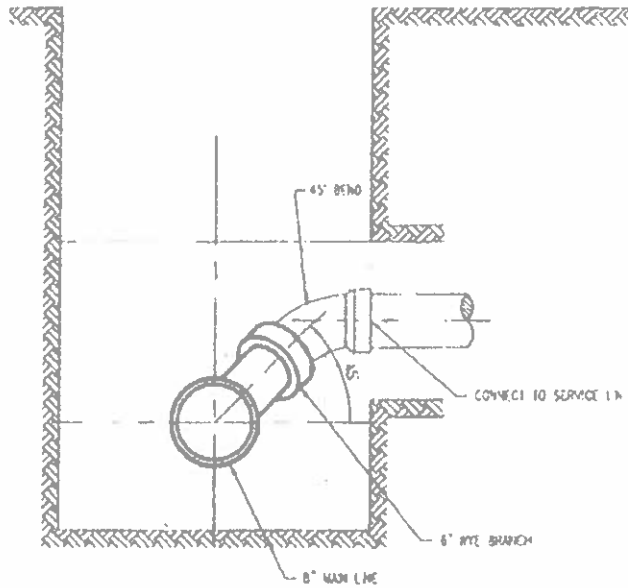

NOTE

1 SANITARY SEWER WYE FITTING MATERIAL MUST BE ASTM D-3034, SDR-35, POLYVINYL CHLORIDE AND SHALL MEET ASTM D 3212 JOINT SPECIFICATIONS



SANITARY SEWER

WYE INSTALLATION

STANDARD DWG NO. SAN-5

